

May 28, 2020

Supplier Quality Notification Sealed Shrink Component Requirements

To our Valued Suppliers:

BAE Systems would like to remind our supplier base of the requirements for sealing shrink components on cable/harness assemblies.

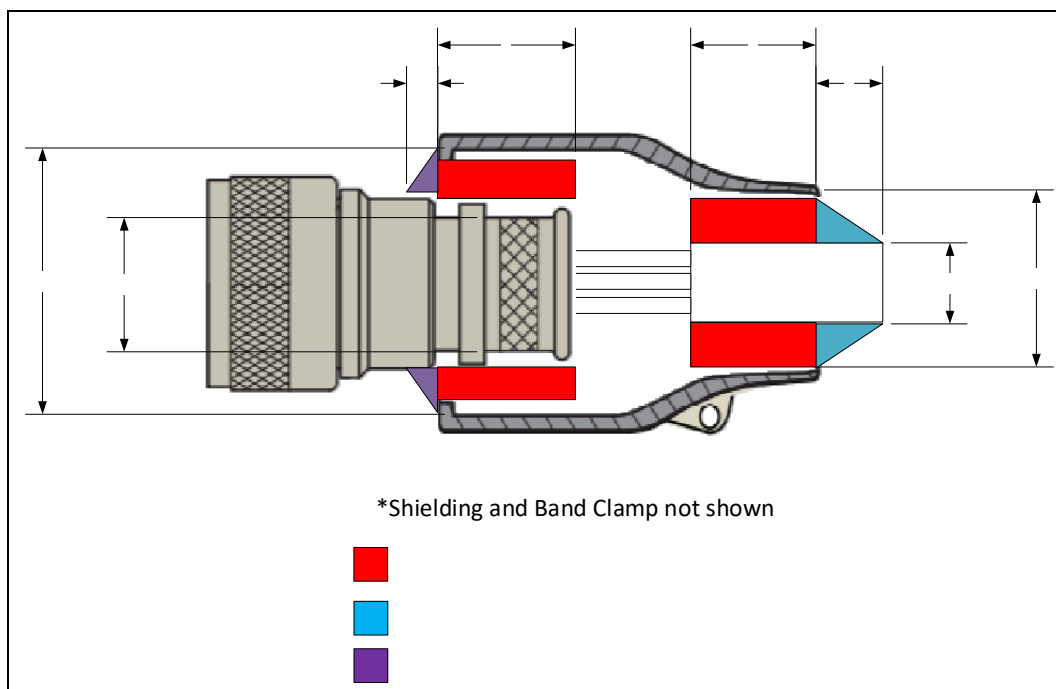

Figure 1 Shrink Boot Sealing Diagram

Shrink Components:

Shrink components shall be installed as specified by the drawing or build specification.

Shrink boots and transitions with pre-installed adhesive shall overlap the cable jacket for the length of the pre-installed adhesive as a minimum, unless otherwise specified by the harness drawing or build specification.

For shrink components with pre-installed adhesive, additional adhesive may be added to ensure a proper bond. Additional adhesive shall be the same material as the pre-installed adhesive, or as specified by the drawing or build specification.

If a specified adhesive is not compatible with pre-installed adhesive, suppliers shall submit a VIR to BAE Systems for guidance.

Shrink component bond surfaces shall be abraded per the adhesive manufacturer's installation instructions if not provided with pre-installed adhesive.

If the minimum inner diameter of a shrink component is greater than or equal to the outer diameter of the connector or backshell that it must bond to, suppliers shall submit a VIR to BAE Systems for guidance.

If the minimum inner diameter of a shrink component is greater than or equal to the outer diameter of the cable jacket that it must bond to, the supplier shall build up the cable diameter per the drawing or build specification. If the drawing or build specification does not provide guidance for building up the cable diameter, suppliers shall submit a VIR to BAE Systems for guidance.

Potting:

Connectors shall be potted in accordance with the drawing or build specification using material specified by the drawing or build specification. Potting shall be free of voids. Suppliers shall document in process inspection for potting, because it is not visible when the assembly is complete.

Overlap:

Shrink component overlap shall be in accordance with the drawing or build specification. Adhesive shall be installed for the full length of shrink component overlap.

Surface Abrasion and Cleaning:

All bonding surfaces, with the exception of connectors and backshells, shall be abraded in accordance with the adhesive manufacturer's installation instructions. Surface abrasion shall extend beyond the shrink component and adhesive fillet (to jacket).

All bonding surfaces shall be cleaned prior to adhesive installation. Cleaning shall remove particles that result from the abrading process as well as remove residues that inhibit adhesion.

Adhesives shall be cured as specified by the drawing, build specification or adhesive manufacturer's installation instructions. In the event that there is a conflict between those documents, suppliers shall submit a VIR to BAE Systems for guidance.

Note: some adhesives require that the connectors be loose during the cure process to prevent pressure build up that can result from adhesive outgassing.

Part Marking and Labeling:

Labels shall be located as specified by the drawing or build specification. Label material and nomenclature shall be as specified by the Supplier Quality Assurance Manual, (SQAM), drawing and build specification. If label location or the specified material reduces flexibility and degrades shrink component adhesion the supplier shall submit a VIR to BAE Systems for guidance.

Terminals:

Terminals with inspection holes and/or open barrel end shall be sealed in accordance with the drawing or build specification.

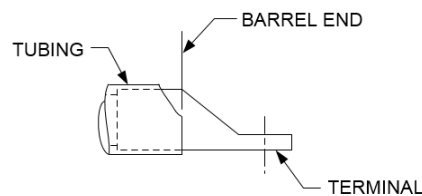

Process Validation:

Suppliers shall perform and maintain records of adhesive installation process validation.

For oven cured adhesives, oven temperature monitoring equipment shall be calibrated. Oven temperatures and cure times shall be documented for each cable/harness assembly.

Peel Test:

- Materials shall be representative of production materials. Each Jacket/Adhesive/Shrink Component combination requires a separate peel test.
- Perform peel test in accordance with ASTM D1876, except under "Procedure" apply the load at a constant head speed of 2 IN/MIN.
- Peel strength test pass criteria shall be 15 LBS/IN width minimum.
- Perform peel test at 6 month intervals as a minimum unless otherwise specified by the purchase order, drawing or build specification.

Inspection Criteria:

Mandrel bend inspection: The mandrel bend inspection below applies to TE Connectivity adhesives. It shall be the default inspection method for shrink component adhesion if the adhesive manufacturer does not specify an inspection method.

Allow harness to cure and follow the manufacturer's post cure handling instructions.

Perform the mandrel bend inspection for each adhesive bond as shown in Figure 2. The adhesive bond shall be subject to a flex test of 90° in each of the four planes around a mandrel. The mandrel diameter shall be 6X the cable diameter +/- 0.5 IN.

*Caution must be exercised to only bend the cable near the adhesive bond as shown. The molded parts (boots and transitions) must not be flexed, only the cable branch. The molded parts may contain terminators, splices and inline components that can be damaged if flexed.

Visually inspect to ensure that the adhesive is intact and has not begun to open or peel at the bond line during or after the mandrel bend test. The bond line is defined as the plane between the edge of the shrink component and the cable jacket. Any separation at the bond line is a failure.

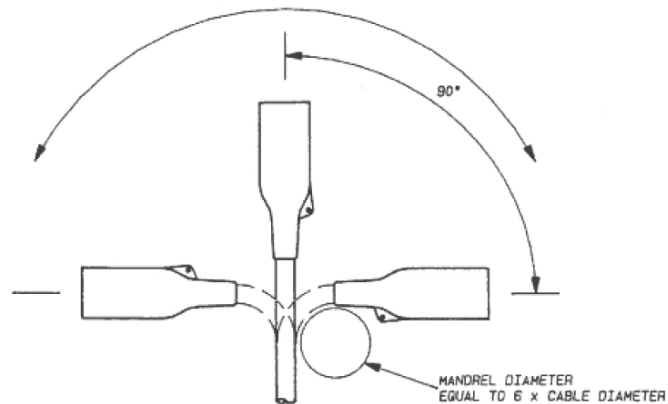

Figure 2 Mandrel Bend Inspection

Adhesive fillet (to jacket) shall extend 0.10 IN MAX from the end of the shrink component unless otherwise specified by the drawing or build specification. If the adhesive fillet separates from the cable jacket it shall be trimmed to verify that there is no separation at the bond line when the mandrel bend inspection is performed.

Adhesive fillet (to backshell) shall be visible and shall show no evidence of separation.

Packaging:

Suppliers shall package harnesses so that minimum bend radius is not violated and the condition of the harness is not degraded during shipping or while in storage. Loose hardware that is needed for the next assembly level should be bagged/tagged and attached to the associated connector or component.

Thank you for your support!